

SHEET 1
REV 4
10110930
SIZE A3
DRAWING NO.

GE PROPRIETARY AND CONFIDENTIAL INFORMATION
This document is the property of General Electric Company ("GE") and contains proprietary information of GE. This document is loaned on the express condition that neither it nor the information contained therein shall be disclosed to others without the express written consent of GE Energy, and that the information shall be used by the recipient only as approved expressly by GE Energy. This document shall be returned to GE upon its request. This document may be subject to certain restrictions under U.S. export control laws and regulations.

REVISIONS				
REV.	DESCRIPTION		DATE	APPROVED
1	R1113523	PRASAD	11-08-12	GUPTA
2	C003310		03-06-15	VS
3	C035056	RAGHAV	12-04-17	SANDEEP
4	C046810	RAGHAV	06-05-18	GUPTA

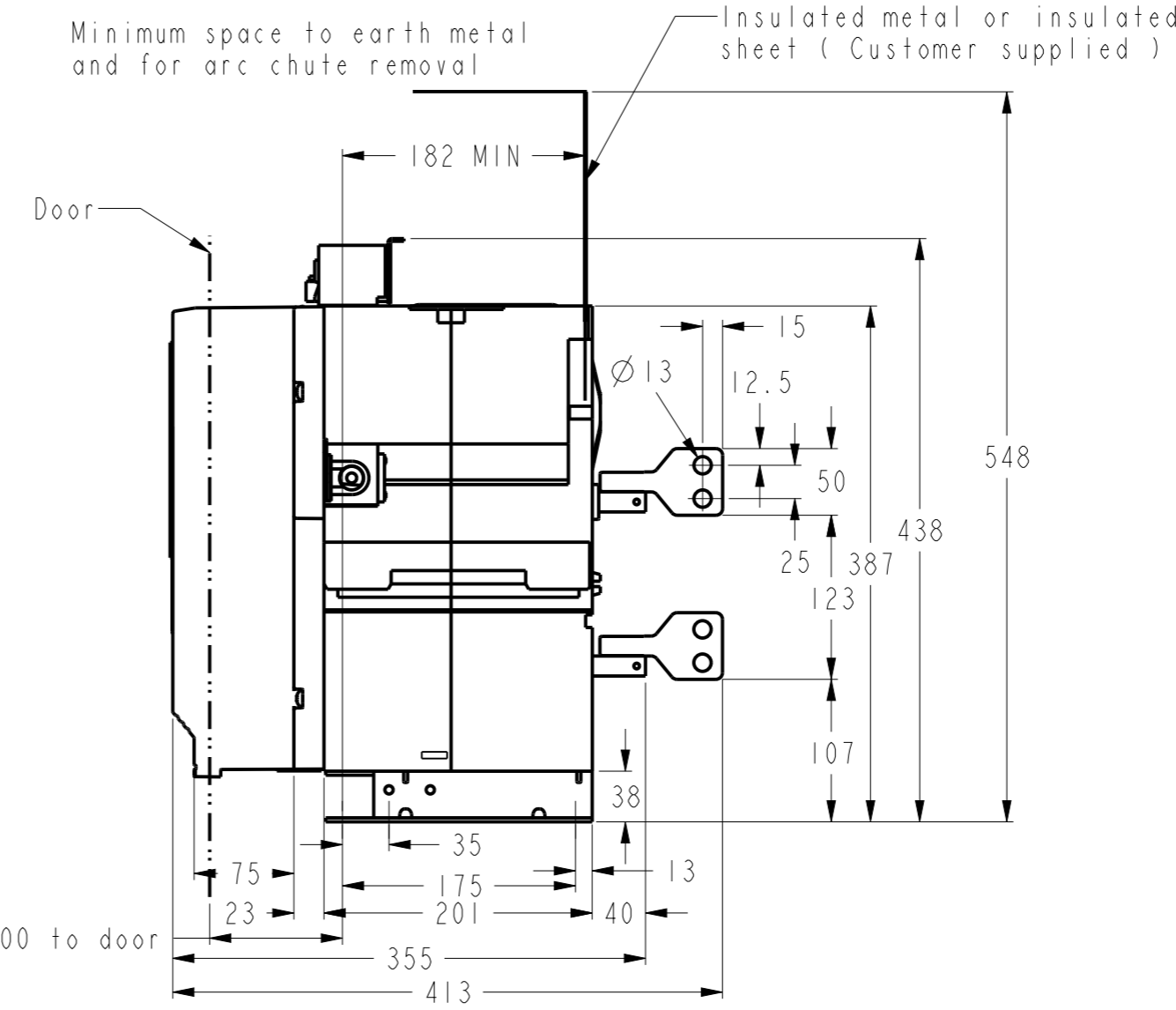
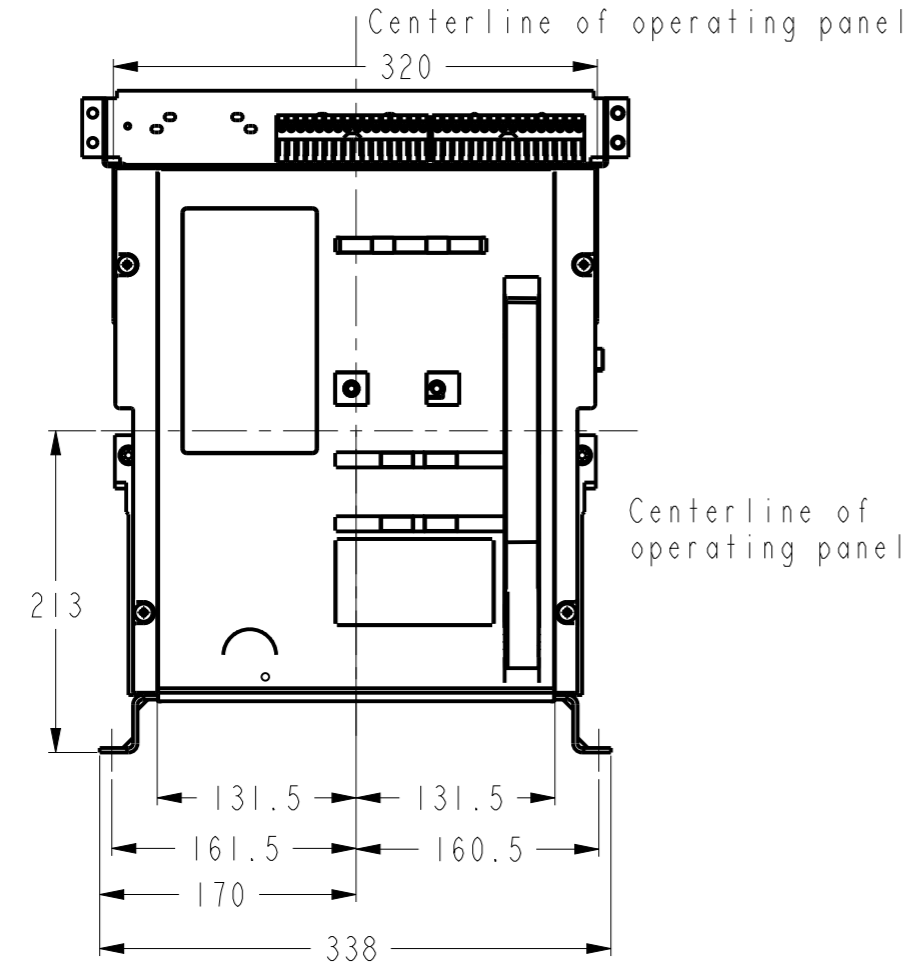
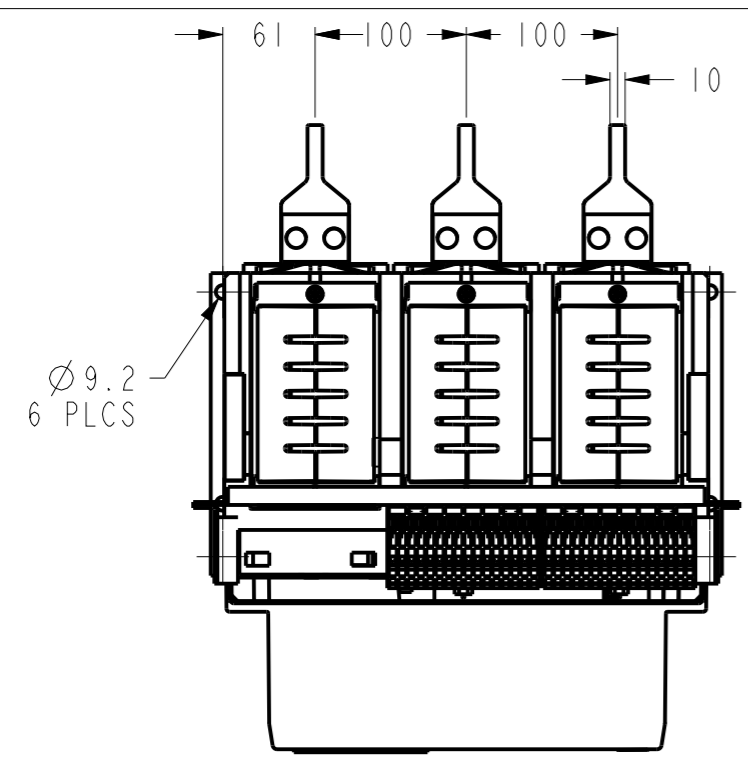

PV1

NOTE:
COPPER WORK MUST BE SUPPORTED WITHIN 200mm OF BREAKER CONNECTIONS - BUS BAR OR CABLES
ALL BUS BAR CONNECTIONS TO BE TIGHTENED TO 50Nm TORQUE

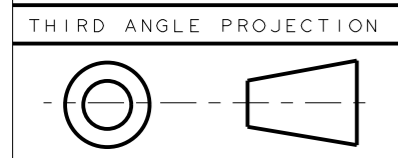

Article or Material Must Conform to REACH Procedure SI900000 Sec. 14
Article or Material Must Conform to RoHS Procedure SI900000 Sec. 13

Part must conform to SI 900000 Sect. 4, Toxicity Procedure

FOR ADDITIONAL INFO REFER TO:		SIGNATURES		DATE
APPLIED PRACTICES	MODEL	PRASAD		11-02-12
DIMENSIONS ARE IN MILLIMETERS	DETAIL	PRASAD		11-02-12
UNLESS OTHERWISE SPECIFIED IN DRAWING	CHECKED	GUPTA		11-02-12
TOLERANCE ON:	ENGRG			
1 PL DECIMALS ± 0.3	MFG			
2 PL DECIMALS ± 0.13	QUALITY			
ANGLES ± 0.5	ISSUED			
FRACTIONS ±	DRAWING FILE:	10110930PVI		
FINISH	SOLID MODEL:	10110930PVI		
CRITICAL TO QUALITY CHARACTERISTIC				

GE Energy

TITLE **OUTLINE VER 1600A 3P, FIXED FRAME 1 ENTELLIGUARD L**

SIZE DRAWING **A3** REV **4**

SCALE: 1:5 REF. No: . SHEET 1 of 1

METRIC