

-NOMENCLATURE-  
 1M,2M-CONTACTORS  
 OL-OVERLOAD RELAY  
 I-INDICATING LIGHT  
 FU-FUSE  
 X-INDICATES CONTACT CLOSED

ALTERNATE LEGENDS FOR FAST AND SLOW ARE HIGH AND LOW

NOTE: ADDITIONAL OVER-CURRENT PROTECTION MAY BE REQUIRED. REFER TO THE NATIONAL ELECTRICAL CODE OR LOCAL ELECTRICAL CODE AS REQUIRED.

FOR EXTRA AUXILIARY CONTACTS- A MAXIMUM OF 2 CONTACTS MAY BE ADDED AT POSITIONS X & Z

FOR CONTROLLER WITHOUT DISCONNECT MEANS- WIRE LINE DIRECT TO L1, L2 AND L3 ON CONTROLLER.

FACTORY SUPPLIED PILOT DEVICES ARE WIRED PER TABLE "B". FOR CONSTANT HP MOTORS, INTERCHANGE WIRES 3 & 5 AND 2 & 4 PER TABLE "A".

FOR SEPARATE CONTROL SOURCE - OMIT WIRE "A" AND CONNECT SEPARATE CONTROL SOURCE TO N/C CONTACT ON OL AND TO 1 ON PILOT DEVICE. WIRE "A" IS OMITTED AT FACTORY ON ALL STARTERS WITH A COIL VOLTAGE OF 120V OR LESS.

MOTOR CONNECTIONS	SPEED	L1	L2	L3	OPEN	TOGETHER
CONSTANT HP	SLOW FAST	T1 T6	T2 T4	T3 T5	T1,T2,T3	T4,T5,T6
CONSTANT TORQUE	SLOW FAST	T1 T6	T2 T4	T3 T5	T6,T4,T5	T1,T2,T3
VARIABLE TORQUE	SLOW FAST	T1 T6	T2 T4	T3 T5	T6,T4,T5	T1,T2,T3

CONNECTION TABLE	CONTROLLER TERMINALS					
	A	B	C	D	E	F
CONSTANT HP	T6	T4	T5	T1	T2	T3
CONSTANT TORQUE	T1	T2	T3	T6	T4	T5
VARIABLE TORQUE	T1	T2	T3	T6	T4	T5

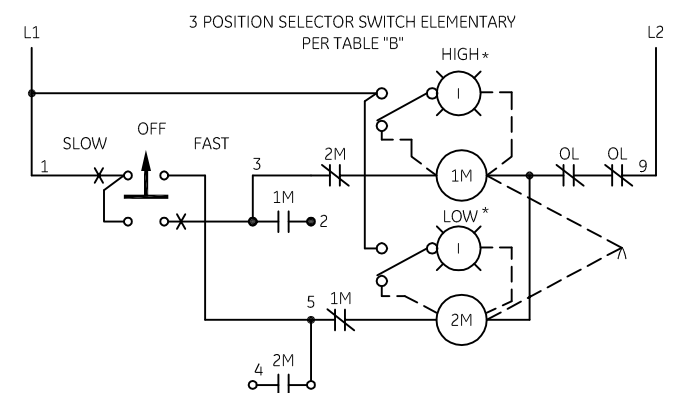
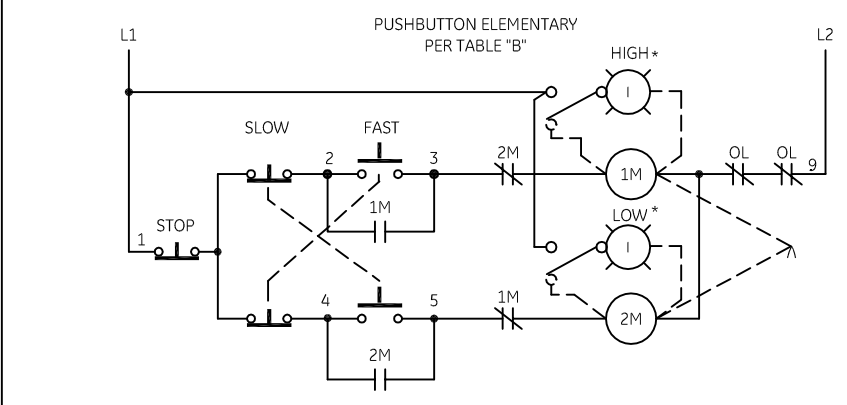
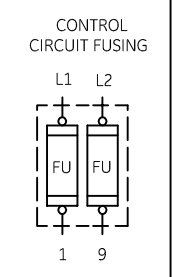
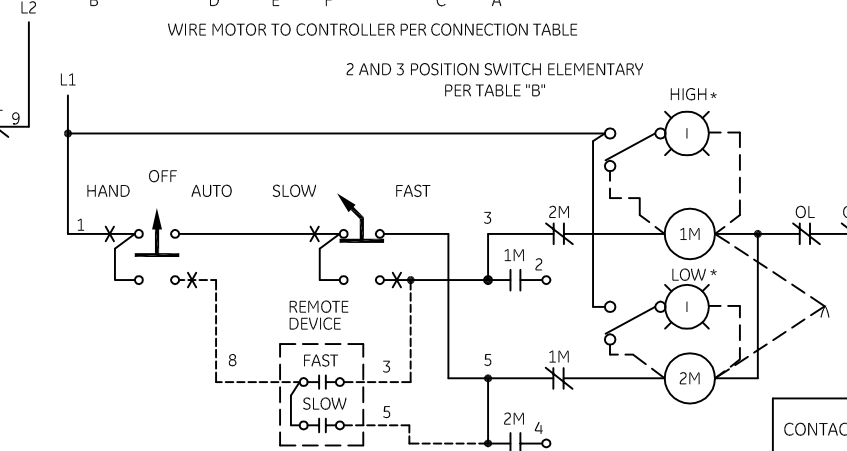
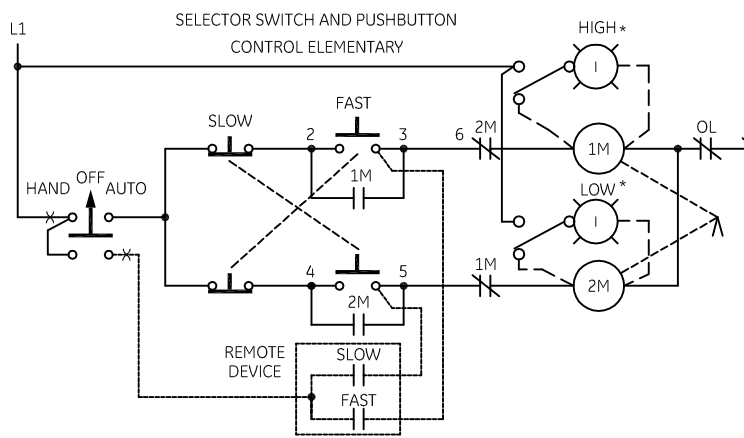
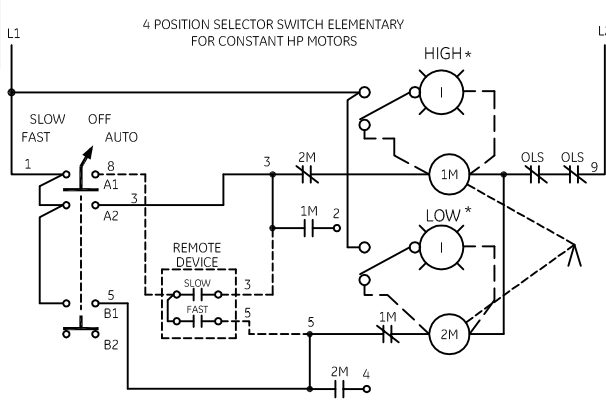
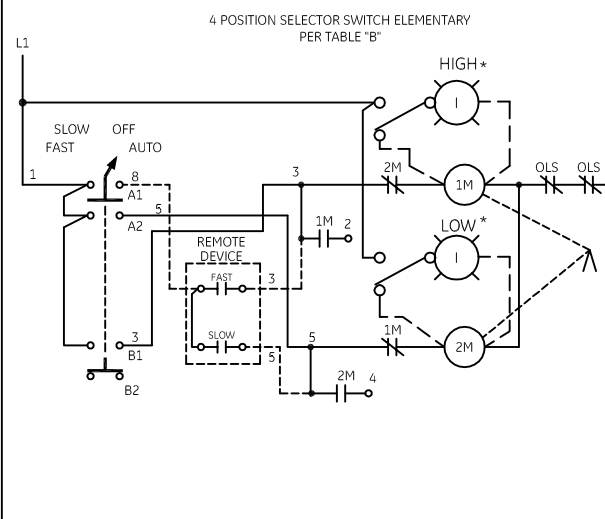
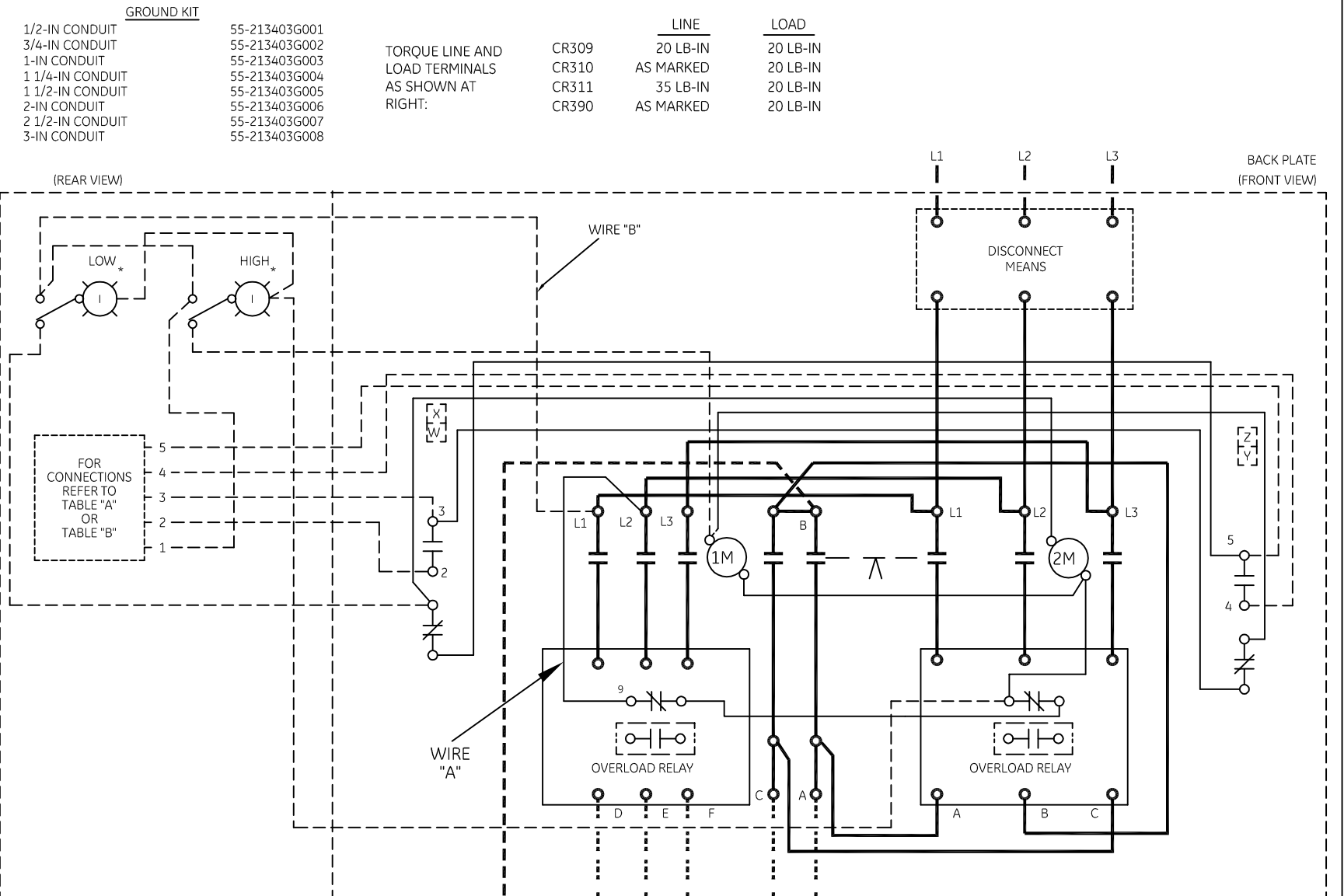
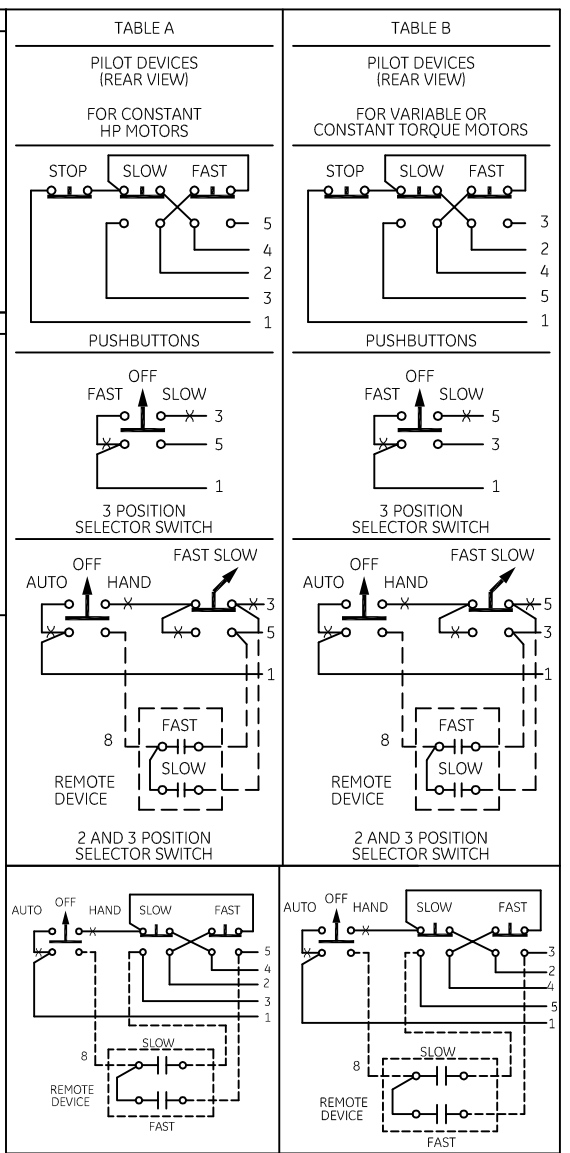
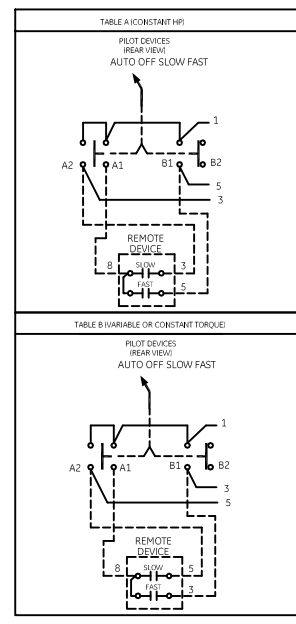

CONTACT	POSITION			
	FAST	SLOW	OFF	AUTO
A1		X		X
A2				
B1	X			
B2			X	

GE imagination at work

WIRING DIAGRAM  
 2 SPEED - 1 WINDING SIZE 0 & 1

AN #	THIRD ANGLE PROJECTION	SHEET #
09-9115		1 OF 1

DWG NO.	DATE	REV
55-537748	09/11/2009	2